

PARTS KEY:

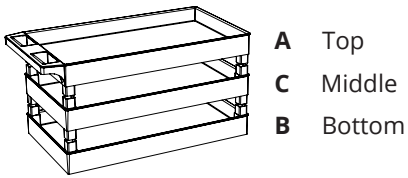

Tub Shelves*
(SEC, EC, STC, and TC models)

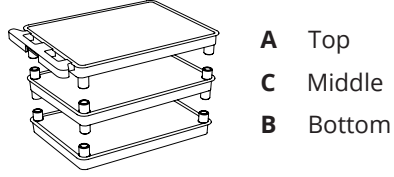

Flat Shelves*
(BC, HE, HC, LE, LP, and WT models)



4" Standard Casters
(All models except for ECHD and XLC)

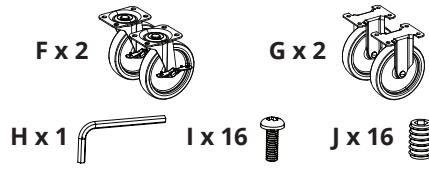

5" Heavy-Duty Casters + Hardware
(ECHD and XLC models)

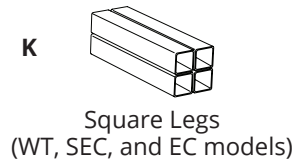

Square Legs
(WT, SEC, and EC models)

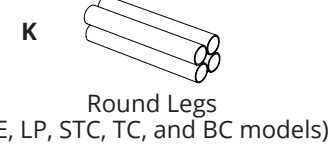

Round Legs
(LE, LP, STC, TC, and BC models)

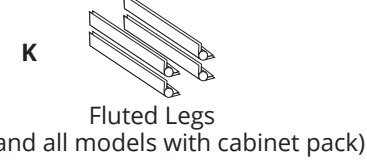

Fluted Legs
(XLC and all models with cabinet pack)

REQUIRED TOOLS:

- Rubber Mallet
(Not included)
- Phillips Head Screwdriver
(ECHD and XLC models only, not included)

IMPORTANT:

If your cart includes options such as a power strip, pullout shelf, locking drawer, or locking cabinet, installation instructions for those components will be included in their packaging.

*NOTE:

Some BC, STC, and TC models come with a mix of flat and tub shelves.

ACCESSORIES (Not included): (For accessory installation, refer to instructions enclosed with each accessory.)

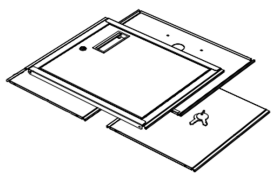

Cabinet Pack

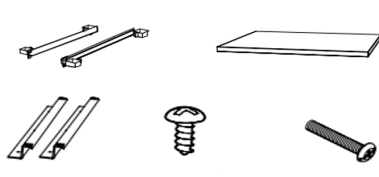

Pullout Shelf + Hardware

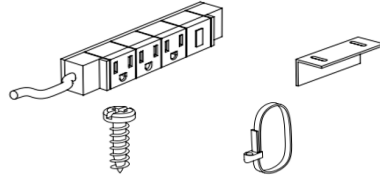

3-Outlet Power Strip + Hardware

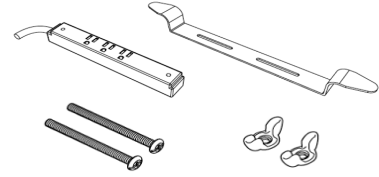

3-Outlet Power Strip with
Cord Wrap + Hardware

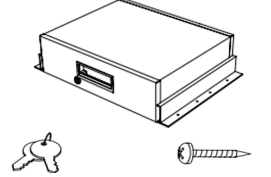

Locking Drawer + Hardware

WHAT'S IN THE BOX:

| Part | Standard 2-Shelf | Standard 3-Shelf | Standard 4-Shelf | Standard 5-Shelf | Standard 6-Shelf | Heavy-Duty 2-Shelf | Heavy Duty 3-Shelf |
|------------------------------|------------------|------------------|------------------|------------------|------------------|--------------------|--------------------|
| Top Shelf (A) | 1 | 1 | 1 | 1 | 1 | 1 | 1 |
| Bottom Shelf (B) | 1 | 1 | 1 | 1 | 1 | 1 | 1 |
| Middle Shelf (C) | 0 | 1 | 2 | 3 | 4 | 0 | 1 |
| Locking 4" Caster (D) | 2 | 2 | 2 | 2 | 2 | 0 | 0 |
| Non-Locking 4" Caster (E) | 2 | 2 | 2 | 2 | 2 | 0 | 0 |
| Locking 5" HD Caster (F) | 0 | 0 | 0 | 0 | 0 | 2 | 2 |
| Non-Locking 5" HD Caster (G) | 0 | 0 | 0 | 0 | 0 | 2 | 2 |
| Allen Wrench (H) | 0 | 0 | 0 | 0 | 0 | 1 | 1 |
| Threaded Insert (I) | 0 | 0 | 0 | 0 | 0 | 16 | 16 |
| Threaded Screw (J) | 0 | 0 | 0 | 0 | 0 | 16 | 16 |
| Legs (K) | 4 | 8 | 12 | 16 | 20 | 4 | 8 |

ASSEMBLY INSTRUCTIONS:

Standard Models

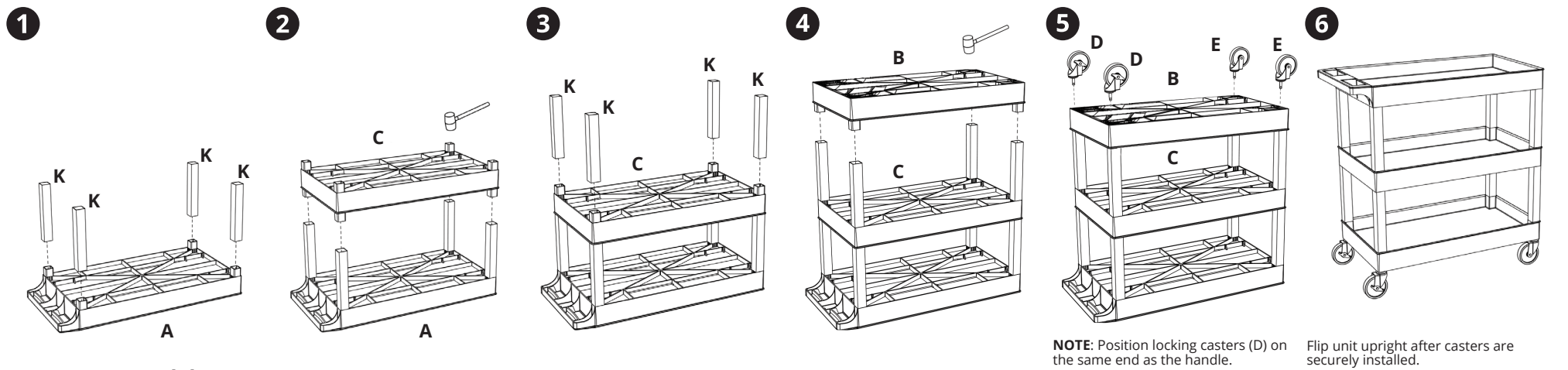

NOTE: Position locking casters (D) on the same end as the handle.

Flip unit upright after casters are securely installed.

Heavy-Duty Models

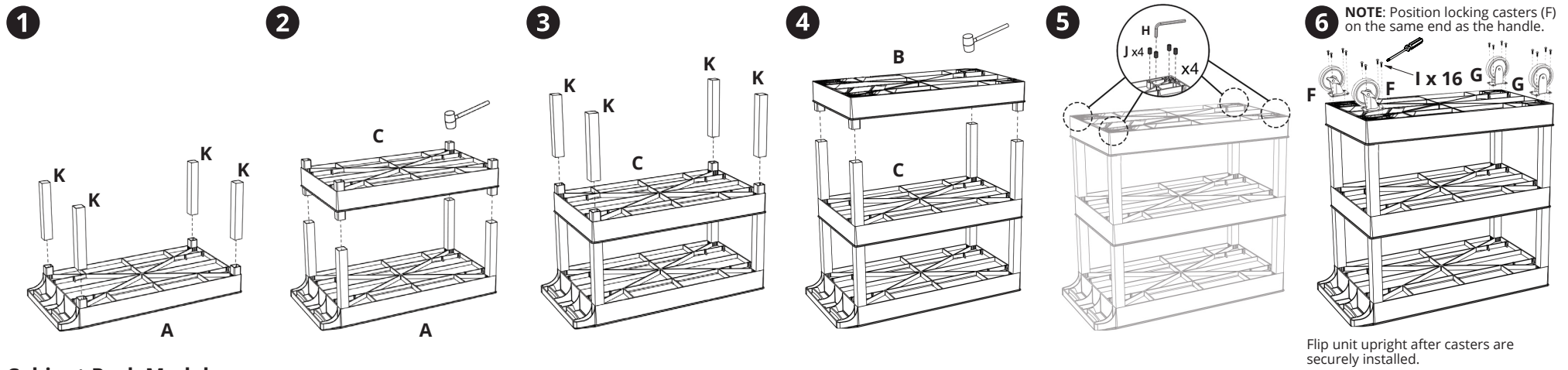

NOTE: Position locking casters (F) on the same end as the handle.

Flip unit upright after casters are securely installed.

Cabinet Pack Models

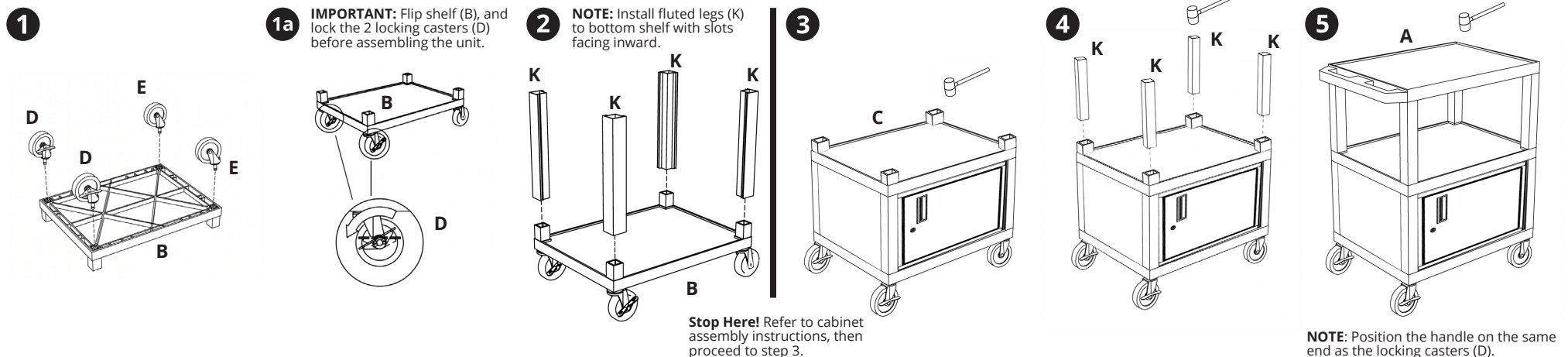

Stop Here! Refer to cabinet assembly instructions, then proceed to step 3.

NOTE: Position the handle on the same end as the locking casters (D).