

The **MedCline Reflux Relief System** is a clinically proven, 100% drug-free solution comprised of three components:

ADVANCED POSITIONING WEDGE

Creates ideal 15-20° angle to elevate the entire torso, while enabling a left side-sleeping position, to provide maximum reflux relief. The arm pocket relieves pressure from the shoulder and prevents sliding down

LATERAL BODY POSITIONER

Ensures positional compliance by keeping the patient on his/her side. Provides additional support to the head, neck, and lower back.

INSERT PILLOW

Provides extra support to the head and neck within the arm pocket of the Advanced Positioning Wedge.

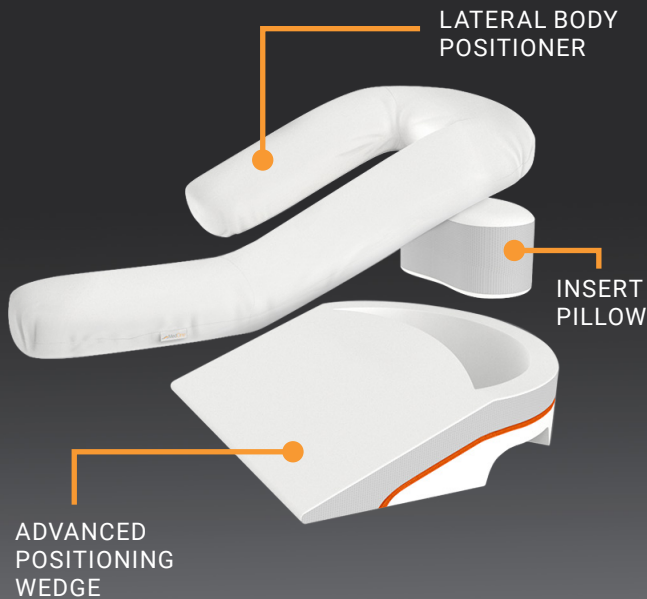

REFLUX RELIEF SYSTEM SPECIFICATIONS

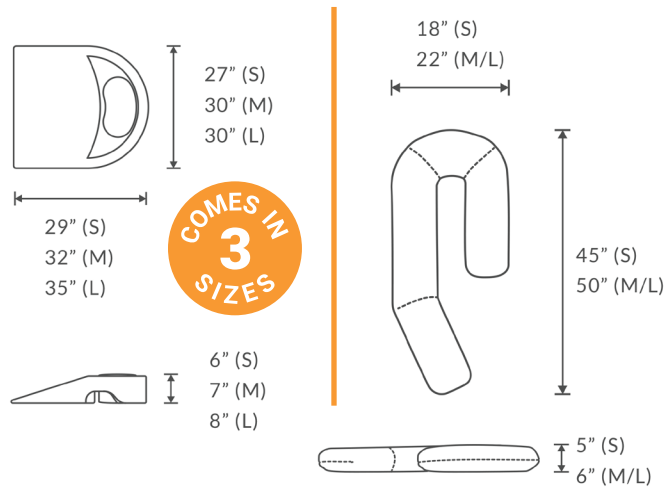

Size selection should be based on patient's height to ensure proper torso fit.



NIGHTTIME ACID REFLUX RELIEF SYSTEM

// FOR VETERANS //



NOW AVAILABLE THROUGH THE VA

REFERENCES:

1. Person, EB, Rife CC, Castell DO, et al. A novel sleep-assist device prevents gastroesophageal reflux: A randomized controlled trial. *Am J Gastroenterology* 2013; 108:S1-S36.
2. Allampati SK, Lopez R, Ray M, Birgisson S, Gabbard SL. Use of a Sleep Positioning Device Significantly Improves Nocturnal Gastroesophageal Reflux Symptoms. *Am J Gastroenterology* 2014; 109:S1-S3
3. Boys JA, Om SA, Patel R, Oh DS, Hagen JA, DeMeester SR. Nocturnal Regurgitation after Esophagectomy Before and After Implementation of a Novel Sleep Assist Device. *Journal of the American College of Surgeons*, October 2015, Vol. 221, Issue 4, S14-S15..

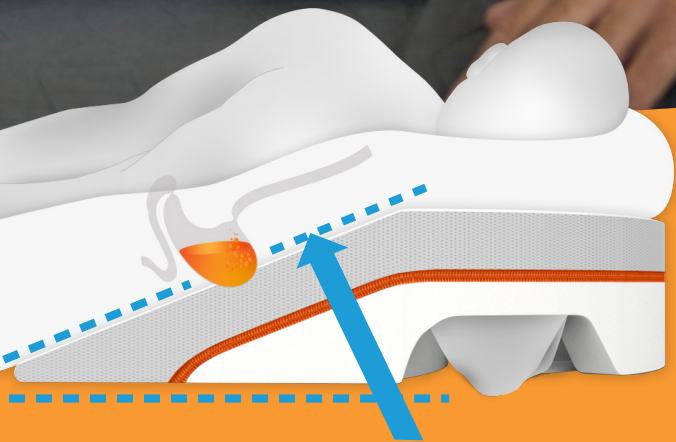

MedCline combines the recommendations for elevated -and- left-side sleeping into a comfortable, at-home solution.

- 87%** Less acid exposure in the esophagus compared to a bed wedge¹
- 89%** Of patients reported a reduction in regurgitation and gagging at night due to reflux²
- 93%** Of patients reported a reduction in nighttime heartburn²
- 95%** Of patients experienced an improvement in sleep quality³

POSITIONING OUR VETERANS FOR NIGHTTIME REFLUX RELIEF

The **MedCline** Reflux Relief System is a three-component Sleep Positioning System validated in 7 independent clinical trials to be most effective treatment for gastroesophageal reflux disease (GERD), heartburn, regurgitation, coughing, choking, nausea, and the many other distressing nocturnal symptoms of acid reflux.

MedCline is the only product available through the VA that maintains the ideal, inclined + left side, sleep position for effective reflux relief.

ORDER THROUGH **THE VA** TODAY!

