

Ultrasonic Humidifier

Use and Care Manual

IMPORTANT!
READ AND
SAVE THESE
INSTRUCTIONS

- ▶ Cool Mist for Relief of Cold and Flu Symptoms
- ▶ Silent Operation
- ▶ 20 Hours Operation Between Fillings

If you have any questions about the operation of your ultrasonic humidifier, call our toll-free Consumer Service line at 1-800-VAPOR-1-2

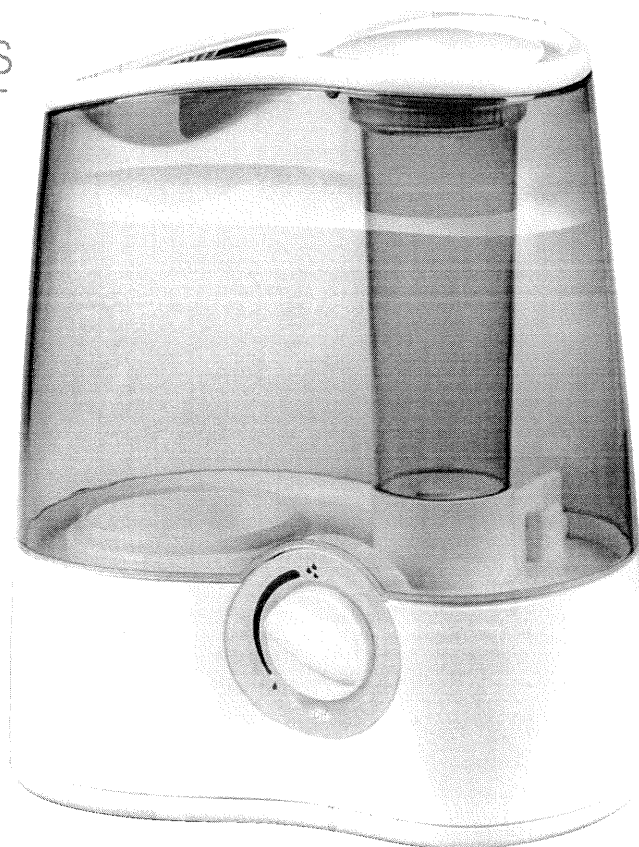

kaz

Manufacturing Quality Healthcare Products for Over 75 Years

Important Safety Instructions

READ ALL INSTRUCTIONS BEFORE USING HUMIDIFIER, ESPECIALLY THESE BASIC SAFETY PRECAUTIONS:

1. Always place humidifier on a firm, flat, level surface. Keep cord away from heated surfaces and out of the way, where it can not be stepped on or tripped over.
2. Before using the humidifier, extend the cord and inspect for any signs of damage. **Do not** use product if cord has been damaged.
3. To avoid the risk of fire, shock or personal injury, **do not** use an extension cord.
4. Humidifier should always be unplugged and emptied when not in operation or while being cleaned. Shut off and unplug humidifier before moving. **Do not** move or tilt humidifier while it is operating. Plug and unplug unit with dry hands.
5. **Do not** operate without water. Turn off unit when tank is empty.
6. **Do not** add any medications (e.g., **do not** add Kaz Inhalant or Vicks VapoSteam) into the Nozzle, Base, Reservoir or Water Tank. **Do not** cover, or insert objects into, any openings on the unit.
7. **Do not** immerse the Base in water or other liquid. **Do not** overfill.
8. **Do not** operate outdoors, this appliance is intended for indoor use.
9. **Do not** place in direct sunlight, high-temperature areas, or near computers or sensitive electronic equipment.
10. This product has a polarized plug (one blade is wider than the other) as a safety feature. This plug will fit into a polarized outlet only one way. If the plug does not fit fully into the outlet, reverse the plug. If it still does not fit, contact a qualified electrician. **Do not** attempt to defeat this safety feature.
11. The humidifier should not be left unattended in a closed room since air could become saturated and leave condensation on walls or furniture. Leave room door partly open. **Do not** aim Mist Nozzle directly at children, walls or furniture.
12. **Do not** place the humidifier directly on wood furniture or other surfaces which could be damaged by water. Protect by placing the humidifier on a non-metallic waterproof surface.
13. **Do not** touch the Nebulizer while the unit is plugged in as burns could result.

Ultrasonic Humidifier

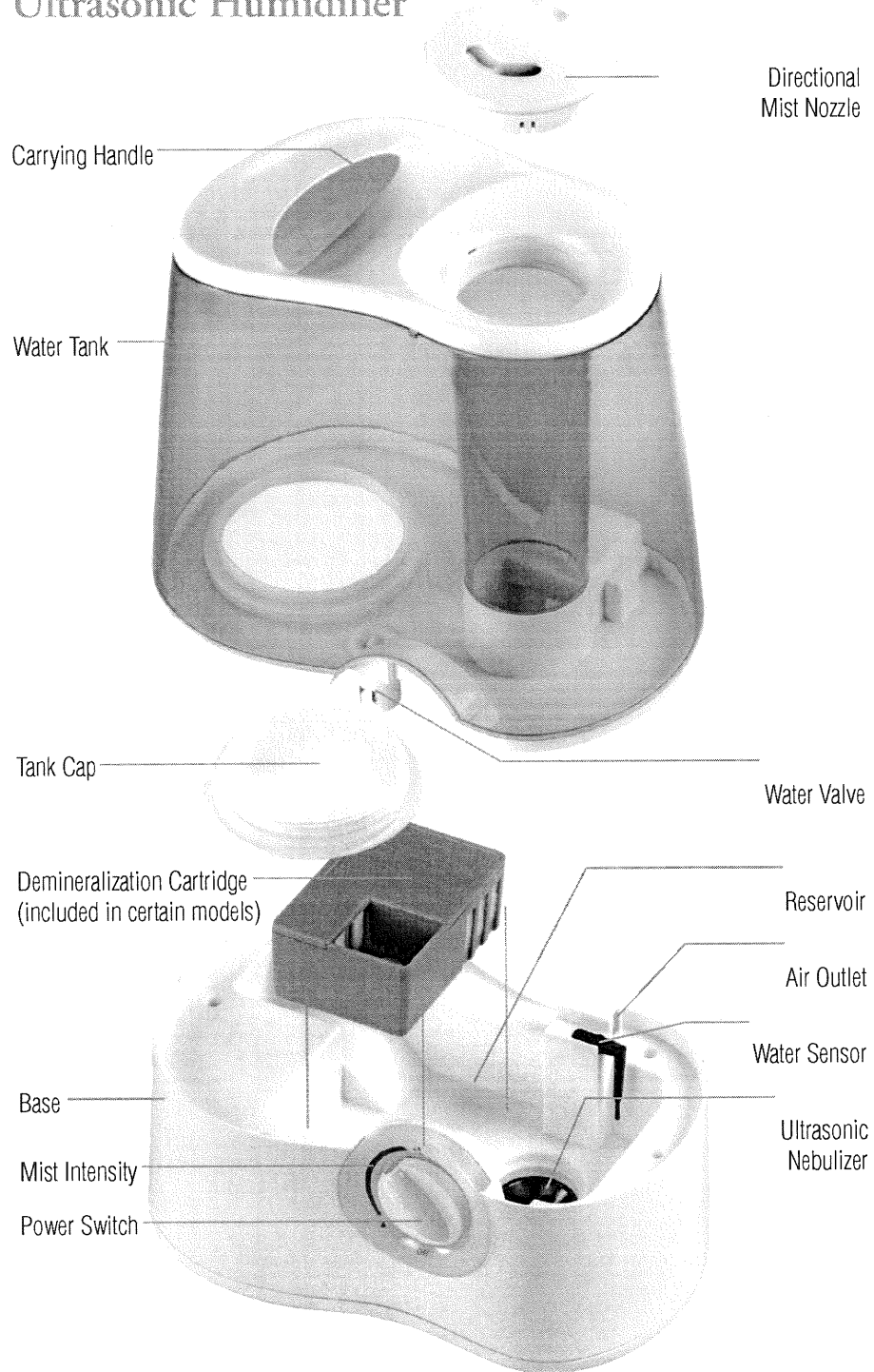

Using Your Ultrasonic Humidifier

First Time Use

Read all instructions before using this appliance.

Unpack and remove all packing material from the Water Tank, Mist Nozzle and Base. Completely unravel power cord and place unit on a flat, stable surface. Remove the protective wrapper from the demineralization cartridge and place into the unit as shown. Follow the directions below to fill and operate the humidifier.

Filling the Water Tank

Always UNPLUG the humidifier before filling.

1. Remove the Water Tank from the Base and turn it upside down. Turn the Tank Cap counterclockwise to open. Rinse and wipe clean.
2. Fill the Water Tank with clean, cool, tap water and replace the Tank Cap by firmly turning clockwise. Turn the Tank upright and check Tank Cap for leaks. If any water drips from Tank Cap, remove it and re-tighten. **Use of very cold water may temporarily reduce the mist output. Never fill the humidifier with hot or warm water as this could cause damage and void your warranty.**

To avoid white dust we recommend using a Kaz Demineralization Cartridge (Model DC-51) and replacing it after 30-40 fillings. If you live in an extremely hard water area you may also wish to use distilled water to further reduce white dust. Refer to *About White Dust*.

3. Inspect the Base and Nebulizer for cleanliness. Refer to *Care and Cleaning* section.
4. Replace the Water Tank on the Base.

Operating Instructions

1. **Do not** operate the humidifier without water in the Water Tank.
2. After filling the humidifier, be sure the Power Switch is in the OFF position, then plug the power cord into a 120 volt AC wall outlet.
3. Turn the Power Switch to the On position and then set.
4. Mist will not appear immediately; allow a few minutes for the water to fill the Reservoir. If you are using a new Demineralization Cartridge, it may take up to fifteen minutes for the filtering material to become saturated and for mist to appear.
5. Direct Mist Nozzle away from walls and furniture. If condensation forms on walls or windows, or if indoor relative humidity exceeds 50%, reduce Mist Intensity Control setting, open door to room where humidifier is operating, or turn unit off.
6. If mist is not produced, unplug cord and check the Water Sensor in the Reservoir to ensure it is in contact with the water. The water level in the Base must be high enough to partially immerse the Water Sensor in order for the humidifier to work.

7. Turn the humidifier off before removing and refilling the Water Tank. When the Tank is empty the mist will stop although the fan will continue to operate.

About White Dust

Use of high-mineral-content water will cause a white mineral residue to accumulate on room surfaces near the humidifier. The mineral residue is commonly called "white dust." The higher the mineral content (the harder your water is), the greater the potential for white dust. The white dust is not caused by a defect in the humidifier, but is due only to minerals suspended in the water.

Kaz Demineralization Cartridge (Model DC-51)

This Humidifier may be supplied with a demineralization cartridge that removes minerals from the water. This prevents the precipitation of minerals ("white dust") that can occur in hard water areas. The demineralization cartridge is designed to last for about a month to two months of normal use; the effective time will vary depending on the mineral content of the water used. If you live in a hard water area, we recommend the use of distilled water for better results from the humidifier.

If you are using distilled water in the humidifier, you may find the demineralization cartridge unnecessary. And, if you choose, you may operate the humidifier without it.

Replacement Cartridge Model DC-51 should be available where you purchased the humidifier. For assistance in locating an outlet near you or to purchase directly from Kaz, please call 1-800-VAPOR12.

Care and Cleaning

CAUTION: ALWAYS TURN OFF THE POWER SWITCH AND DISCONNECT THE POWER CORD FROM THE ELECTRICAL OUTLET BEFORE CLEANING.

Daily Maintenance:

1. Lift the Water Tank from Base and empty all water from the Reservoir. Remove the Tank Cap and drain any water from the Water Tank. Wipe it clean with a soft, damp cloth. The Mist Nozzle should be removed during cleaning to prevent damage.
2. **Do not** immerse the Base in water. Gently wipe the Reservoir with a soft, clean, wet cloth. **Do not** attempt to remove or in any other way modify the Water Sensor. **Use care** when wiping around the Water Sensor; it is delicate and can be easily damaged. Rinse the Water Tank with lukewarm water after each use. For storage, wipe dry with a soft, clean cloth. Keep water away from the Air Outlet.
3. **Do not** use detergent to clean any water-containing parts of the humidifier. Detergents and the film they leave behind can affect the output of the humidifier. **Do not** use abrasive cleansers or brushes.

4. **Do not** leave water in the Water Tank or Reservoir when unit is not in use as it may result in the build up of mineral deposits and bacteria that can inhibit the output efficiency of the humidifier. Please note that if water remains in the Water Tank for more than a day or two, bacterial growth is possible.

Weekly Maintenance:

1. Thoroughly clean humidifier every week using a solution of bleach and water (one teaspoon of bleach in one gallon of water). Fill Tank partially with this solution, let stand twenty (20) minutes, shaking vigorously every few minutes, drain and rinse with clean water until the bleach smell is gone.
2. Wipe the Reservoir with a soft cloth dampened in the solution. Rinse area thoroughly before proceeding.
3. If mineral deposits are evident around the Nebulizer and Water Sensor, clean their surfaces with a soft, clean cloth and a small amount of undiluted white vinegar. If necessary for removal of mineral deposits, mix a solution of 50% white vinegar and 50% water and fill the Base with enough solution to cover the Nebulizer. Allow it to soak for an hour. Then use a cotton swab to gently loosen buildup on the Nebulizer. Rinse out the Reservoir and wipe clean. **Do not touch Nebulizer with bare fingers** as any fingerprints or other residue can affect mist output. Be careful not to damage the Water Sensor.
4. All surfaces should be thoroughly cleaned with water prior to reuse.

End of Season Maintenance

1. Follow above weekly cleaning procedure at the end of the humidification season, or when the humidifier will not be used for several days, being sure to dry all parts, including the inside of the Water Tank. **Do not** store with water inside.
2. Leave Tank Cap partially loosened during storage to prevent Tank Cap and gasket from sticking together. This will prolong the life of the gasket.
3. Clean the Tank and Base after long periods of storage.

Troubleshooting Guide

If your Humidifier is not working properly, refer to the following:

Problem	Possible Cause	Solution
Power Switch is set to "On" and Power Light is off	<ul style="list-style-type: none"> • Unit not plugged in • No power at outlet 	<ul style="list-style-type: none"> • Plug unit in • Check circuits, fuses, try a different outlet.
Little or no mist is produced	<ul style="list-style-type: none"> • No water in tank • Unit is not level • Mineral deposits on Nebulizer or Water Sensor • Water Tank was washed with detergent • Blower not operating • Demineralization Cartridge is clogged • Nebulizer not functioning 	<ul style="list-style-type: none"> • Fill Water Tank. • Place on a level surface. • Clean Nebulizer and Water Sensor per instructions. • Rinse thoroughly with clean water. Wipe Dry. • Ensure water in Base is adequate to immerse Water Sensor. • Remove Cartridge and restart machine. If mist resumes, replace with a new Cartridge (#DC-51). • See Warranty
Condensation forms around humidifier or windows	<ul style="list-style-type: none"> • Mist Intensity is set too high for room size or preexisting humidity level. 	<ul style="list-style-type: none"> • Decrease mist output using the Mist Intensity Control.
White Dust Accumulation	<ul style="list-style-type: none"> • Hard water used • Demineralization Cartridge needs replacement 	<ul style="list-style-type: none"> • Use distilled water or a Demineralization Cartridge. • Replace Demineralization Cartridge (Model DC-51)

Note: Failure to keep this unit clean from mineral deposits normally contained in any water supply will affect the efficiency of operation of this unit. Customer failure to follow these instructions may void the warranty.

Warranty

This Ultrasonic Humidifier is warranted against defective material or workmanship for a period of one year from the date of purchase. Any defective part will be repaired or replaced at no charge if it has not been tampered with and appliance has been used according to these printed directions. Warranty does not cover the demineralization cartridge; performance of the demineralization cartridge depends on the mineral content of the water used in the humidifier. This Warranty gives you specific legal rights as well as other rights which vary from state to state.

If you experience unsatisfactory operation, first refer to the troubleshooting section above to ensure that it is not due to care or cleaning. Follow *Care and Cleaning* instructions.

If you have any questions or comments, call the Kaz Consumer Service Department at (800) 477-0457 or, write to Kaz, Humidifier Service Dept., One Vapor Trail, Hudson, NY 12534, explaining just how the product is operating. Specify model number. Our Consumer Service Representative will advise you how to correct the problem yourself, or will ask you to return the product for repair or replacement.

kaz *Manufacturing Quality Healthcare Products for Over 70 Years*

Kaz, Incorporated
One Vapor Trail
Hudson, NY • USA • 12534

The Vicks Ultrasonic Humidifier is
distributed by Kaz, Inc. under license from
The Procter & Gamble Company, Cincinnati, OH 45202.

Vicks and VapoSteam
are registered trademarks of
The Procter & Gamble Company

©1998, Kaz, Incorporated
Made and printed in China